



**5**  
YEARS  
WARRANTY

**ROHS**  
COMPLIANT

**REACH**  
COMPLIANT



Medical



Automation



Datacom



IPC



Industry



Measurement



Telecom



Automobile



Boat



Charger



PV



Railway

UL US CB CE UK CA



<b>2</b> X MOPP	<b>4000</b> VAC Reinforced Insulation	<b>ADJ.</b> Output Voltage	<b>Internal</b> EN55032 Class <b>B</b> Filter	<b>LOW</b> Leakage Current	<b>LOW</b> Standby Power	<b>Protection</b> Class I Class II	<b>Operating</b> Altitude <b>5000</b> meter	<b>OCP</b>	<b>OVP</b>	<b>SCP</b>
-----------------------	--	----------------------------------	--	----------------------------------	--------------------------------	--	--	------------	------------	------------

### PART NUMBER STRUCTURE

<b>M</b>	<b>A</b>	<b>D</b>	<b>100</b>	<b>U</b>	<b>S</b>	<b>12</b>	<b>B</b>	-	<input type="checkbox"/>
Application	Package Code	Dimension Code	Output Power (W)	Input Voltage (VAC)	Output Quantity	Output Voltage (VDC)	Protection Type		Connector Options
<b>Medical Application</b>	A: Open type U: U chassis type E: Enclosed type D: Din rail type			U: Universal 85 ~ 264VAC	S: Single	12: 12V 15: 15V 18: 18V 24: 24V 28: 28V 36: 36V 48: 48V	B: CLASS II <input type="checkbox"/> : CLASS I		<input type="checkbox"/> : JST M: Molex T: Terminal Block

**TECHNICAL SPECIFICATION** All specifications are typical at 230VAC input, full load and 25°C unless otherwise noted

Model Number	Input Range VAC	Output Voltage VDC	Output Current Natural Convection A	Input Power No Load W	Efficiency %	Maximum Capacitor Load µF
MAD100US12B MUD100US12B MED100US12B MDD100US12B	85 ~ 264	12	8.34	0.3	91	6950
MAD100US15B MUD100US15B MED100US15B MDD100US15B	85 ~ 264	15	6.67	0.3	92	4450
MAD100US18B MUD100US18B MED100US18B MDD100US18B	85 ~ 264	18	5.56	0.3	92	3100
MAD100US24B MUD100US24B MED100US24B MDD100US24B	85 ~ 264	24	4.17	0.3	92	1750
MAD100US28B MUD100US28B MED100US28B MDD100US28B	85 ~ 264	28	3.58	0.3	92	1280
MAD100US36B MUD100US36B MED100US36B MDD100US36B	85 ~ 264	36	2.78	0.3	91	770
MAD100US48B MUD100US48B MED100US48B MDD100US48B	85 ~ 264	48	2.09	0.3	91	430

## INPUT SPECIFICATIONS

Parameter	Conditions	Min.	Typ.	Max.	Unit
Operating input voltage range	AC input	85		264	VAC
	DC input	120		370	VDC
Input frequency	AC input	47		63	Hz
Input current	115VAC and Full Load			1.15	A
	230VAC and Full Load			0.55	
No load input power	230VAC			0.3	Watts
Leakage current	264VAC			75	µA
Power Factor		0.95			
Start up time				1000	ms
Rise time			20		ms
Hold up time	115VAC and Full Load	16			ms
Input inrush current	230VAC			60	A
Input protection	Internal fuse in line and neutral			T3.15A/250VAC	

OUTPUT SPECIFICATIONS						
Parameter	Conditions		Min.	Typ.	Max.	Unit
Output power					100	Watts
Initial set voltage accuracy	230VAC and Full Load		-1.0		+1.0	%
Line regulation	Low Line to High Line at Full Load		-0.2		+0.2	%
Load regulation	No Load to Full Load		-0.5		+0.5	%
	10% Load to 90% Load		-0.4		+0.4	%
Voltage adjustability			-10		+10	%
Minimum load				0		%
Ripple and noise	Measured by 20MHz bandwidth					
	With a 10µF/25V 1206 X7R MLCC	12Vout		120		
		15Vout		150		
		18Vout		160		
	With a 1µF/50V 1206 X7R MLCC	24Vout		160		mVp-p
		28Vout		180		
		36Vout		190		
	With a 0.1µF/100V 1206 X7R MLCC	48Vout		340		
Temperature coefficient			-0.02		+0.02	%/°C
Transient response	Load step from 50 ~ 75% change at 2.5A/µs	Peak deviation			3	% Vout
		Recovery time		500		µs
Over voltage protection	% of Vout(nom); Latch mode		115		135	%
Over load protection	% of Iout rated; Hiccup mode		115		150	%
Short circuit protection			Continuous, automatic recovery			

GENERAL SPECIFICATIONS						
Parameter	Conditions		Min.	Typ.	Max.	Unit
Isolation voltage	1 minute (2MOPP insulation)	Input to Output	4000			VAC
		Input (Output) to F.G.	1500			
Isolation resistance	500VDC		0.1			GΩ
Switching frequency		Others		60		kHz
		18Vout		80		
Safety approvals	IEC/ EN/ ANSI/AAMI ES 60601-1 IEC/ EN/ UL 62368-1					UL:E360199 UL:E193009 CB:UL(Demko)
Weight		MAD				156g (5.50oz)
		MUD				194g (6.84oz)
		MED				210g (7.41oz)
		MDD				232g (8.18oz)
MTBF	MIL-HDBK-217F Ta=25°C, Full load					7.903 x 10 <sup>5</sup> hrs

ENVIRONMENTAL SPECIFICATIONS						
Parameter	Conditions		Min.	Typ.	Max.	Unit
Operating ambient temperature	Natural convection	With derating	-25		+85	°C
Storage temperature range			-40		+85	°C
Operating altitude					5000	m
Shock						IEC60068-2-27
Vibration						IEC60068-2-6
Relative humidity	Non-condensing					5% to 95% RH

EMC SPECIFICATIONS		
Parameter	Conditions	Level
EMI	EN55011, EN55032, EN60601-1-2 and FCC Part 18 / 15 External components may be required for class I application.	Conducted ClassB Radiated ClassA
Harmonic currents	EN61000-3-2 Full Load	Class A and D
Voltage flicker	EN61000-3-3	
EMS	EN55024 and EN60601-1-2	
ESD	EN61000-4-2	Perf. Criteria A
Radiated immunity	EN61000-4-3 20 V/m	Perf. Criteria A
Fast transient	EN61000-4-4 ± 2kV	Perf. Criteria A
Surge	EN61000-4-5 DM ± 1kV and CM ± 2kV	Perf. Criteria A
Conducted immunity	EN61000-4-6 20 Vr.m.s	Perf. Criteria A
Power frequency magnetic field	EN61000-4-8 30A/m	Perf. Criteria A
Dip and interruptions	EN61000-4-11	

## CHARACTERISTIC CURVE

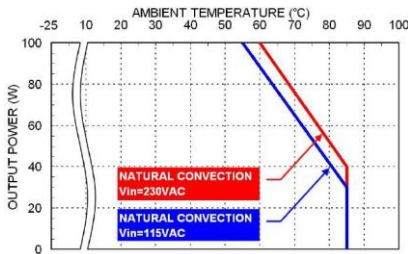

Derating Curve vs. Ambient Temperature  
MED100 & MDD100

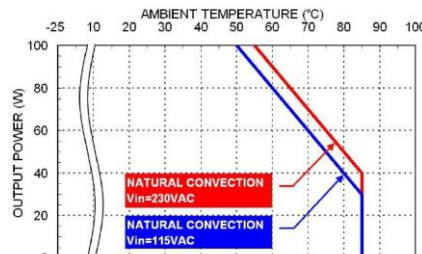

Derating Curve vs. Ambient Temperature  
MAD100 & MUD100

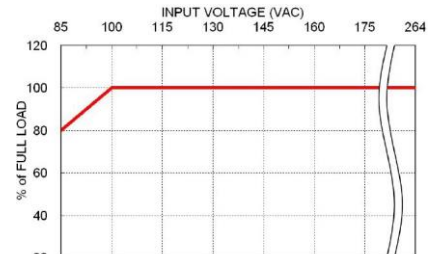

Derating Curve vs. Input Voltage  
MD100

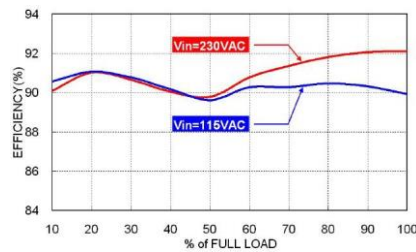

Efficiency vs. Output Load  
MD100US24B

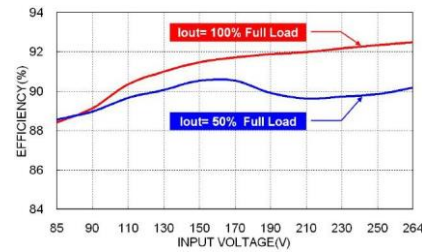

Efficiency vs. Input Voltage  
MD100US24B

## MECHANICAL DRAWING

MAD Open type

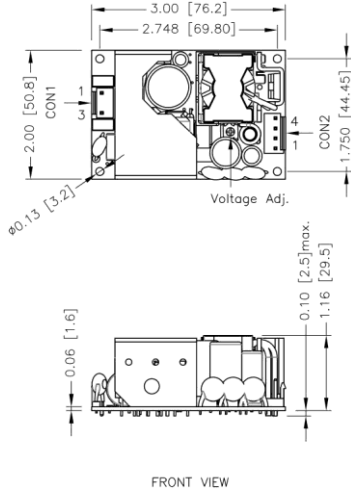

MDD Din rail type

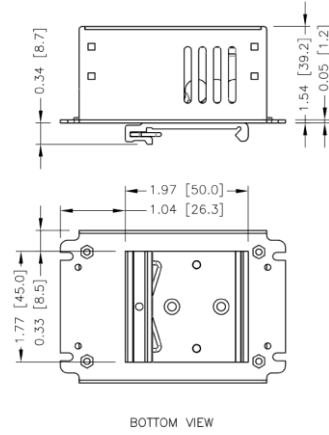

1. All dimensions in inch [mm]
2. Tolerance : x.xx±0.02 [x.x±0.5] x.xxx±0.01 [x.xx±0.25]
3. M3x0.5 screw locked torque MAX 5Kgf.cm/0.49N.m

### CONNECTORS CONNECTIONS

CON1 – Input Connector	
Pin 1	Line
Pin 3	Neutral

CON2 – Output Connector	
Pin 1,2	-Vout
Pin 3,4	+Vout

\*Either one of four screws holes of Open / Chassis type can be considered as PE connection for CLASS I application.

## MECHANICAL DRAWING(CONTINUED)

**MED** Open type

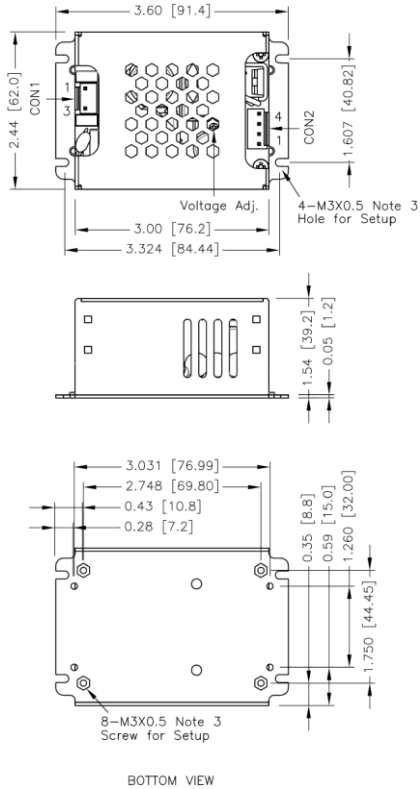

**MUD** Din rail type

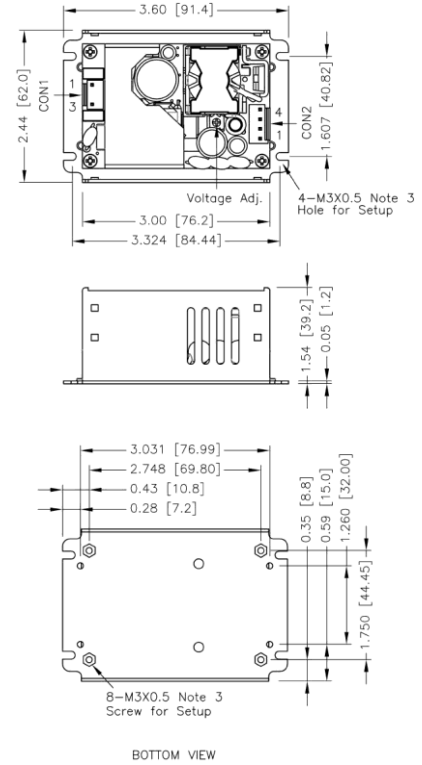

1. All dimensions in inch [mm]
2. Tolerance : x.xx±0.02 [x.x±0.5] x.xxx±0.01 [x.xx±0.25]
3. M3x0.5 screw locked torque MAX 5Kgf.cm/0.49N.m



### CONNECTORS CONNECTIONS

CON1 – Input Connector	
Pin 1	Line
Pin 3	Neutral

CON2 – Output Connector	
Pin 1,2	-Vout
Pin 3,4	+Vout

\*Either one of four screws holes of Open / Chassis type can be considered as PE connection for CLASS I application.

### CONNECTOR OPTIONS

Blank:	JST Type	-M Molex Type	-T Terminal Block
	Mates with housing CON1: VHR-3N CON2: VHR-4N	Mates with housing CON1: 09-50-8031 CON2: 09-50-8041	
	Crimp terminals CON1: SVH-21T-P1.1 CON2: SVH-21T-P1.1	Crimp terminals CON1: SD-2478 CON2: SD-2478	
			Wire dimension range 26 ~ 16AWG