



Power Mate Technology, Inc MAD65 Multi Series

2 X 3.5 Inch AC-DC POWER SUPPLIES
Up to 65 Watts

5
YEARS
WARRANTY

ROHS
COMPLIANT

REACH
COMPLIANT

+85°C
-40°C
AMBIENT TEMP.



Medical



Automation



Datacom



IPC



Industry



Measurement



Telecom



Automobile



Boat



Charger



PV



Railway

UL US CB CE UK CA

FC POWER SAVE

2 x MOPP	4000 VAC Isolation Voltage	ADJ. Output Voltage	Internal EN55032 Class Filter B	LOW Cross Reg.	LOW Leakage Current	LOW Standby Power	Operating Altitude 5000 meter	Protection Class I Class II	OPP	OVP	SCP
-----------------------	--	----------------------------------	---	-----------------------------	----------------------------------	--------------------------------	---	-----------------------------------	------------	------------	------------

PART NUMBER STRUCTURE

MAD	65	U	□	□	□	□	□	C	- xx	yy	- □	
Series Name	Output Power (W)	Input Voltage (VAC)	Output Quantity	Output Voltage 1 (VDC)	Output Voltage 2 (VDC)	Output Voltage 3 (VDC)	Output Voltage 3 Polarity	Output Voltage 3 (VDC)	Protection Type	Vo2 Voltage Code	Vo3 Voltage Code	Connector Options
				Vo1	Vo2	Vo3 (Triple only)						
A: Open type		U: Universal	D: Dual	3: 5V	1: 2.5V	M: Minus	1: 2.5V	C: CLASS I				□: JST
U: U chassis type		85 - 264	T: Triple	4: 7.5V	2: 3.3V	□: Positive	2: 3.3V	D: CLASS II				M: Molex
E: Enclosed type				5: 9V	3: 5V		3: 5V	□: CLASS I				T: Terminal Block
D: Din rail type				6: 12V	x: refer to		4: 7.5V	□: CLASS II				
				7: 15V	Suffix xx		5: 9V	(×NRND)				
				8: 18V			6: 12V	B: CLASS II				
				9: 24V			7: 15V	(×NRND)				
				0: 28V			8: 18V					
							9: 24V					
							y: refer to	×NRND: Not recommended for new designs				
							Suffix yy					

TECHNICAL SPECIFICATION All specifications are typical at 230VAC input, full load and 25°C unless otherwise noted

Model Number	Output 1			Output 2			Output 3		Max. Output Power W	Efficiency %	Maximum Capacitor Load µF
	Voltage VDC	Current (Normal) A	Current (MAX) A	Voltage VDC	Current (Normal) A	Current (MAX) A	Voltage VDC	Current (MAX) A			
MAD65UD32C MUD65UD32C MED65UD32C MDD65UD32C	+5	6	10	+3.3	6	8	---	---	50	88.5	12000 / 3000
MAD65UD63C MUD65UD63C MED65UD63C MDD65UD63C	+12	3	5.42	+5	6	8	---	---	65	90	2500 / 3000
MAD65UD62C MUD65UD62C MED65UD62C MDD65UD62C	+12	3	5.42	+3.3	6	8	---	---	65	89.5	2500 / 3000
MAD65UD73C MUD65UD73C MED65UD73C MDD65UD73C	+15	2.4	4.34	+5	6	8	---	---	65	90.5	1200 / 3000
MAD65UD93C MUD65UD93C MED65UD93C MDD65UD93C	+24	1.5	2.71	+5	6	8	---	---	65	89	625 / 3000
MAD65UD03C MUD65UD03C MED65UD03C MDD65UD03C	+28	1.25	2.33	+5	6	8	---	---	65	88	390 / 3000
MAD65UT32M3C MUD65UT32M3C MED65UT32M3C MDD65UT32M3C	+5	6	10	+3.3	6	8	-5	0.6	50	88	12000 / 3000 / 500
MAD65UT326C MUD65UT326C MED65UT326C MDD65UT326C	+5	6	10	+3.3	6	8	+12	0.6	50	88	12000 / 3000 / 500
MAD65UT32M6C MUD65UT32M6C MED65UT32M6C MDD65UT32M6C	+5	6	10	+3.3	6	8	-12	0.6	50	88	12000 / 3000 / 500
MAD65UT63M3C MUD65UT63M3C MED65UT63M3C MDD65UT63M3C	+12	3	5.42	+5	6	8	-5	0.6	65	89.5	2500 / 3000 / 500
MAD65UT63M6C MUD65UT63M6C MED65UT63M6C MDD65UT63M6C	+12	3	5.42	+5	6	8	-12	0.6	65	89	2500 / 3000 / 500
MAD65UT623C MUD65UT623C MED65UT623C MDD65UT623C	+12	3	5.42	+3.3	6	8	+5	0.6	65	89	2500 / 3000 / 500

Model Number	Output 1			Output 2			Output 3		Max. Output Power	Efficiency	Maximum Capacitor Load
	Voltage	Current (Normal)	Current (MAX)	Voltage	Current (Normal)	Current (MAX)	Voltage	Current (MAX)			
	VDC	A	A	VDC	A	A	VDC	A			
MAD65UT62M6C MUD65UT62M6C MED65UT62M6C MDD65UT62M6C	+12	3	5.42	+3.3	6	8	-12	0.6	65	88.5	2500 / 3000 / 500
MAD65UT73M7C MUD65UT73M7C MED65UT73M7C MDD65UT73M7C	+15	2.4	4.34	+5	6	8	-15	0.6	65	89.5	1200 / 3000 / 500
MAD65UT936C MUD65UT936C MED65UT936C MDD65UT936C	+24	1.5	2.71	+5	6	8	+12	0.6	65	88.5	625 / 3000 / 500
MAD65UT93M6C MUD65UT93M6C MED65UT93M6C MDD65UT93M6C	+24	1.5	2.71	+5	6	8	-12	0.6	65	88.5	625 / 3000 / 500

INPUT SPECIFICATIONS						
Parameter	Conditions	Min.	Typ.	Max.	Unit	
Operating input voltage range	AC input	85		264	VAC	
	DC input	120		370	VDC	
Input frequency	AC input	47		63	Hz	
Input current	100VAC			1.65	A	
	240VAC			0.95		
No load input power	230VAC		0.15		Watts	
Leakage current	264VAC		75		µA	
Start up time				1000	ms	
Rise time			20		ms	
Hold up time	115VAC and Full Load		16		ms	
Input inrush current	230VAC		60		A	
Input protection	Internal fuse in line and neutral				T3.15A/250VAC	

OUTPUT SPECIFICATIONS						
Parameter	Conditions		Min.	Typ.	Max.	Unit
Output power	Pout 1+Pout 2+Pout 3	Vout 1 5V Others			50 65	Watts
Initial set voltage accuracy	230VAC and Full Load	Vout 1 Vout 2, Vout 3	-1.0 -2.0		+1.0 +2.0	%
Line regulation	Low Line to High Line at Full Load		-0.2		+0.2	%
Load regulation	No Load to Full Load	Vout 1	-0.5		+0.5	%
		Vout 3	-0.7		+0.7	%
Load regulation	No Load to Full Load 0.1W Load to Full Load	Vout 2	-1.5		+1.5	%
			-0.7		+0.7	%
Cross regulation	Asymmetrical load 25%/100% FL		-1.5		+1.5	%
Voltage adjustability		Vout 1	-10		+10	%
Minimum load	M□D65UD□□□ M□D65UT□□□□; Vout 3 is full load	Vout 1 + Vout 2		0 0.5		W
Ripple and noise	Measured by 20MHz bandwidth					
	With a 10µF/25V 1206 X7R MLCC With a 1µF/50V 1206 X7R MLCC	Vout 1 5V		100		mVp-p
		Vout 1 12V		120		
		Vout 1 15V		150		
	With a 10µF/25V 1206 X7R MLCC With a 10µF/25V 1206 X7R MLCC	Vout 2 All		100		
		Vout 3 5V		100		
Vout 3 12V 15V			120 150			
Temperature coefficient			-0.02		+0.02	%/°C
Transient response	Load step from 50 ~ 75% change at 2.5A/µs	Vout 1 Peak deviation Recovery time		600	3	% Vout µs
Over voltage protection	% of Vout(nom); Latch mode	Vout 1	125		140	%
Over power protection	% of nominal output power; Hiccup mode	Pout 1+Pout 2		145		%
Short circuit protection			Continuous, automatic recovery			

GENERAL SPECIFICATIONS						
Parameter	Conditions		Min.	Typ.	Max.	Unit
Isolation voltage	1 minute (2MOPP insulation)	Input to Output Input (Output) to F.G.	4000 2500			VAC
Isolation resistance	500VDC		0.1			GΩ
Switching frequency	230VAC	Vout 1 5V		60		kHz
		Vout 2 Others		115		
		Vout 3		750 510		
Safety approvals	IEC/ EN/ ANSI/AAMI ES 60601-1 IEC/ EN/ UL 62368-1					UL:E360199 UL:E193009 CB:UL(Demko)
Weight		MAD				155g (5.47oz)
		MUD				203g (7.16oz)
		MED				221g (7.80oz)
		MDD				243g (8.57oz)
MTBF	MIL-HDBK-217F, Full load					1.059 x 10 ⁶ hrs

ENVIRONMENTAL SPECIFICATIONS						
Parameter	Conditions		Min.	Typ.	Max.	Unit
Operating ambient temperature	Natural convection	With derating	-40		+85	°C
Storage temperature range			-40		+85	°C
Operating altitude					5000	m
Shock						IEC60068-2-27
Vibration						IEC60068-2-6
Relative humidity	Non-condensing					5% to 95% RH

EMC SPECIFICATIONS			
Parameter	Conditions		Level
EMI	EN55011, EN55032, EN60601-1-2 and FCC Part 18 / 15		Conducted Class B Radiated Class B
	External components may be required for class I application		
Harmonic currents	EN61000-3-2	Full Load	Class A
Voltage flicker	EN61000-3-3		
EMS	EN55024 and EN60601-1-2		
ESD	EN61000-4-2		Perf. Criteria A
Radiated immunity	EN61000-4-3	20 V/m	Perf. Criteria A
Fast transient	EN61000-4-4	$\pm 2kV$	Perf. Criteria A
Surge	EN61000-4-5	DM $\pm 1kV$ and CM $\pm 2kV$	Perf. Criteria A
Conducted immunity	EN61000-4-6	20 Vr.m.s	Perf. Criteria A
Power frequency magnetic field	EN61000-4-8	30 A/m	Perf. Criteria A
Dip and interruptions	EN61000-4-11		

CHARACTERISTIC CURVE

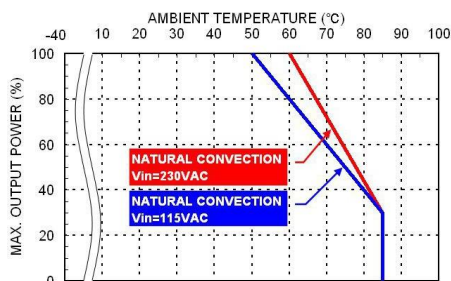

Derating Curve vs. Ambient Temperature
M□D65UD

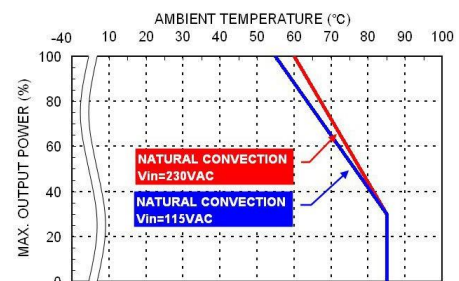

Derating Curve vs. Ambient Temperature
M□D65UT

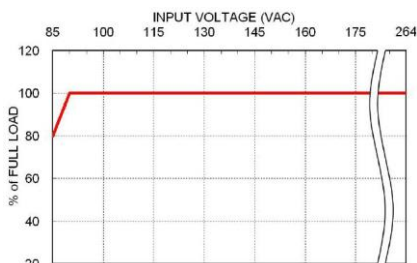

Derating Curve vs. Input Voltage
M□D65

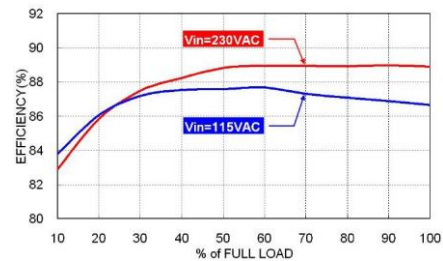

Efficiency vs. Output Load
M□D65UT63M6B

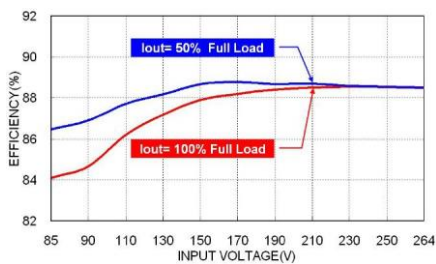

Efficiency vs. Input Voltage
M□D65UT63M6B

MECHANICAL DRAWING

MAD Open type

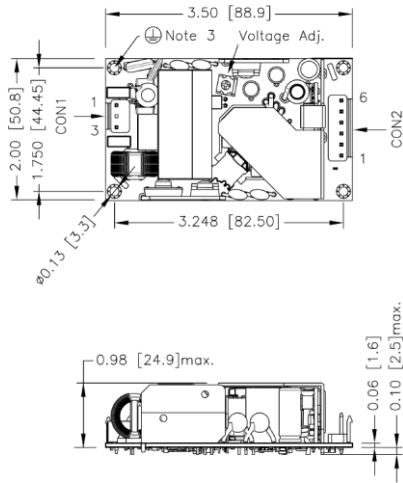

FRONT VIEW

1. All dimensions in inch[mm]
Tolerance: x.xx±0.02[x.x±0.5] x.xxx±0.010[x.xx±0.25]
2. The screw locked torque: MAX 5.0kgf-cm/0.49N-m
3. The screws holes can be considered as PE connection for CLASS I application.

MDD Din rail type

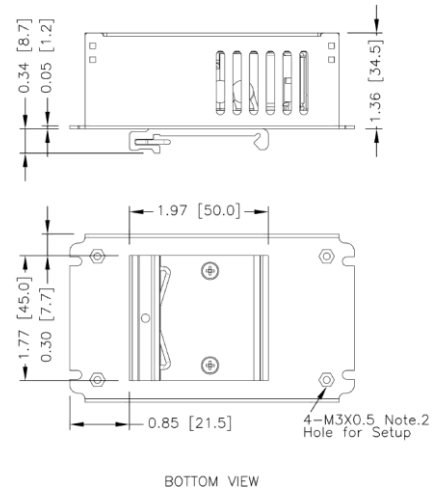

BOTTOM VIEW

1. All dimensions in inch[mm]
Tolerance: x.xx±0.02[x.x±0.5] x.xxx±0.010[x.xx±0.25]
2. The screw locked torque: MAX 5.0kgf-cm/0.49N-m

MED Enclosed type

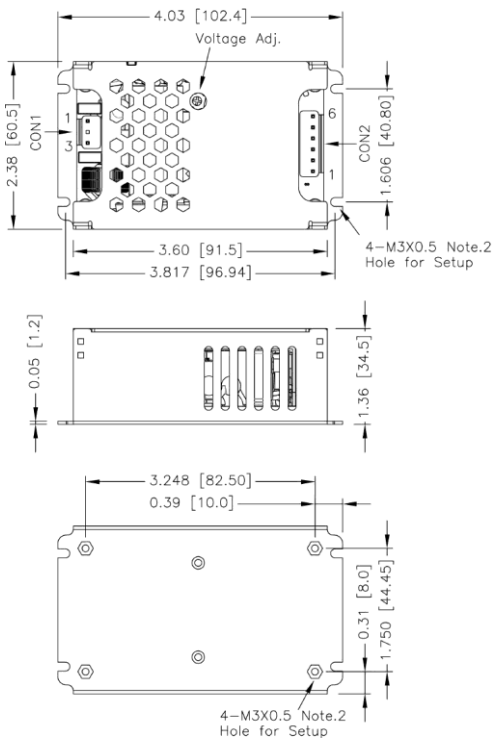

BOTTOM VIEW

1. All dimensions in inch[mm]
Tolerance: x.xx±0.02[x.x±0.5] x.xxx±0.010[x.xx±0.25]
2. The screw locked torque: MAX 5.0kgf-cm/0.49N-m

MUD U chassis type

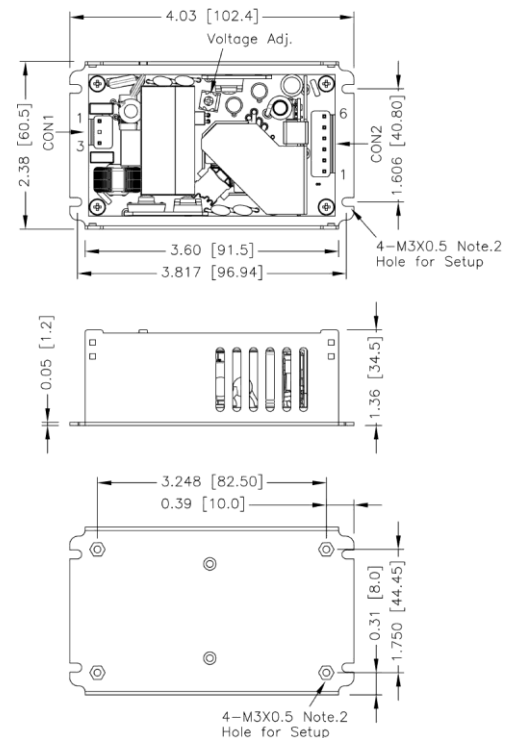

BOTTOM VIEW

1. All dimensions in inch[mm]
Tolerance: x.xx±0.02[x.x±0.5] x.xxx±0.010[x.xx±0.25]
2. The screw locked torque: MAX 5.0kgf-cm/0.49N-m

CONNECTOR CONNECTIONS

CON1 – Input Connector

Pin Number	AC Input	DC Input
		M□D65UDXXC, M□D65UDXXD M□D65UTXXC, M□D65UTXXD
Pin 1	Line	DC+
Pin 3	Neutral	DC-

CON2 – Output Connector

Pin 1	Vout3
Pin 2,3	Com
Pin 4,5	Vout2
Pin 6	Vout1

*Either one of four screws holes of Chassis type can be considered as PE connection for CLASS I application.

CONNECTOR OPTIONS

Blank:

JST Type



Mates with housing
CON1: VHR-3N
CON2: VHR-6N

Crimp terminals
CON1: SVH-21T-P1.1
CON2: SVH-21T-P1.1

-M

Molex Type



Mates with housing
CON1: 09-50-8031
CON2: 09-50-8061

Crimp terminals
CON1: SD-2478
CON2: SD-2478

-T

Terminal Block



Screw locked torque
MAX 2Kgf.cm/0.2N.m

Wire dimension range
26 ~ 16AWG