



3
YEARS
WARRANTY

ROHS
COMPLIANT

REACH
COMPLIANT



Automation



Datacom



IPC



Industry



Measurement



Telecom



Automobile



Boat



Charger



Medical



PV



Railway



3000
VDC
Isolation
Voltage

1600
VDC
Isolation
Voltage

4 : 1
Wide
Input
Range

TINY
Output
Ripple

NO
Min. Load
Required

REMOTE
ON
OFF

SCP

PART NUMBER STRUCTURE

PDS03	-	48	S	05	W	H
Series Name		Input Voltage (VDC)	Output Quantity	Output Voltage (VDC)	Input Range	Isolation Options
PDS : SMD type PDH : DIP type		12:4.5~18 24:9~36 48:18~75	S:Single D:Dual	3P3 :3.3 05 :5 09 :9 12 :12 15 :15 05 :±5 12 :±12 15 :±15	4 : 1	<input type="checkbox"/> :Standard type 1600VDC isolation H :3000VDC isolation

TECHNICAL SPECIFICATION All specifications are typical at nominal input, full load and 25°C unless otherwise noted

Model Number	Input Range	Output Voltage	Output Current @Full Load	Input Current @ No Load	Efficiency	Maximum Capacitor Load
	VDC	VDC	mA	mA	%	µF
PDS(H)03-12S3P3W	4.5 ~ 18	3.3	700	35	75	3300
PDS(H)03-12S05W	4.5 ~ 18	5	600	35	81	1680
PDS(H)03-12S09W	4.5 ~ 18	9	333	35	80	1000
PDS(H)03-12S12W	4.5 ~ 18	12	250	35	82	820
PDS(H)03-12S15W	4.5 ~ 18	15	200	35	82	680
PDS(H)03-12D05W	4.5 ~ 18	±5	±300	40	79	±1000
PDS(H)03-12D12W	4.5 ~ 18	±12	±125	40	82	±470
PDS(H)03-12D15W	4.5 ~ 18	±15	±100	45	81	±330
PDS(H)03-24S3P3W	9 ~ 36	3.3	700	20	75	3300
PDS(H)03-24S05W	9 ~ 36	5	600	20	80	1680
PDS(H)03-24S09W	9 ~ 36	9	333	20	80	1000
PDS(H)03-24S12W	9 ~ 36	12	250	20	82	820
PDS(H)03-24S15W	9 ~ 36	15	200	20	82	680
PDS(H)03-24D05W	9 ~ 36	±5	±300	20	79	±1000
PDS(H)03-24D12W	9 ~ 36	±12	±125	20	82	±470
PDS(H)03-24D15W	9 ~ 36	±15	±100	20	81	±330
PDS(H)03-48S3P3W	18 ~ 75	3.3	700	13	75	3300
PDS(H)03-48S05W	18 ~ 75	5	600	13	80	1680
PDS(H)03-48S09W	18 ~ 75	9	333	13	80	1000
PDS(H)03-48S12W	18 ~ 75	12	250	13	83	820
PDS(H)03-48S15W	18 ~ 75	15	200	13	82	680
PDS(H)03-48D05W	18 ~ 75	±5	±300	13	79	±1000
PDS(H)03-48D12W	18 ~ 75	±12	±125	13	82	±470
PDS(H)03-48D15W	18 ~ 75	±15	±100	13	81	±330

INPUT SPECIFICATIONS

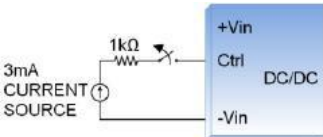
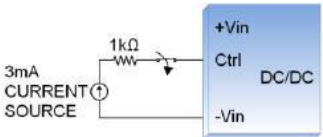
Parameter	Conditions	Min.	Typ.	Max.	Unit
Operating input voltage range	12Vin(nom)	4.5	12	18	VDC
	24Vin(nom)	9	24	36	
	48Vin(nom)	18	48	75	
Start up time	Constant resistive load	Power up	5		ms
		Remote ON/OFF	5		
Input surge voltage	1 second, max.	12Vin(nom)		25	VDC
		24Vin(nom)		50	
		48Vin(nom)		100	
Input filter		Capacitor type			
Remote ON/OFF	Ctrl pin applied current via 1kΩ	DC-DC ON	Open or high impedance		
		DC-DC OFF	2	3	4
		Remote off input current		2.5	mA
<p>Application circuit</p> <p>DC-DC ON</p>  <p>DC-DC OFF</p> 					

OUTPUT SPECIFICATIONS						
Parameter	Conditions		Min.	Typ.	Max.	Unit
Voltage accuracy			-1.0		+1.0	%
Line regulation	Low Line to High Line at Full Load		-0.2		+0.2	%
Load regulation	No Load to Full Load	Single	-1.0		+1.0	%
		Dual	-1.0		+1.0	
	10% Load to 100% Full Load	Single	-0.5		+0.5	%
		Dual	-0.8		+0.8	
Cross regulation	Asymmetrical load 25%/100% FL	Dual	-5.0		+5.0	%
Ripple and noise	20MHz bandwidth			30		mVp-p
Temperature coefficient			-0.02		+0.02	%/°C
Transient response recovery time	25% load step change			250		µs
Short circuit protection			Continuous, automatic recovery			

GENERAL SPECIFICATIONS						
Parameter	Conditions		Min.	Typ.	Max.	Unit
Isolation voltage	1 minute	Input to Output	1600		3000	VDC
Isolation resistance	500VDC		1			GΩ
Isolation capacitance					50	pF
					50	
Switching frequency	Full load to minimum load		100			kHz
Safety approvals	IEC/ EN/ UL62368-1					UL:E193009 CB:UL(Demko)
Weight						4.5g (0.16oz)
MTBF	MIL-HDBK-217F					5.738 x 10 ⁶ hrs

ENVIRONMENTAL SPECIFICATIONS						
Parameter	Conditions		Min.	Typ.	Max.	Unit
Operating ambient temperature	Without derating		-40		+71	°C
	With derating		+71		+85	
Maximum case temperature					100	°C
Storage temperature range			-55		+125	°C
Thermal shock						MIL-STD-810F
Vibration						MIL-STD-810F
Relative humidity						5% to 95% RH
Lead-free reflow solder process	Only for SMD type					IPC J-STD-020E
Moisture sensitivity level(MSL)	Only for SMD type					IPC J-STD-033C Level 2a

EMC SPECIFICATIONS			
Parameter	Conditions	Level	
EMI	EN55032	With external components	
EMS	EN55024		
ESD	EN61000-4-2	Air ± 8kV and Contact ± 6kV	
Radiated immunity	EN61000-4-3	10 V/m	
Fast transient	EN61000-4-4	± 2kV	
		With an external input filter capacitor (Nippon chemi-con KY series, 220µF/100V)	
Surge	EN61000-4-5	±1kV	
		With an external input filter capacitor (Nippon chemi-con KY series, 220µF/100V)	
Conducted immunity	EN61000-4-6	10 Vr.m.s	
Power frequency magnetic field	EN61000-4-8	100A/m continuous; 1000A/m 1 second	

CAUTION: This power module is not internally fused. An input line fuse must always be used.

CHARACTERISTIC CURVE

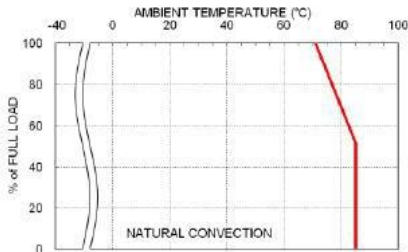

PDS03-48S05W Derating Curve

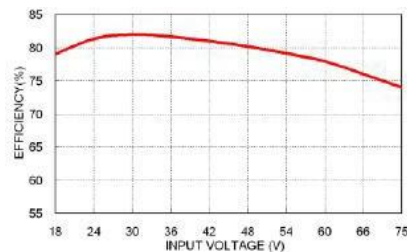

PDS03-48S05W Efficiency vs. Input Voltage

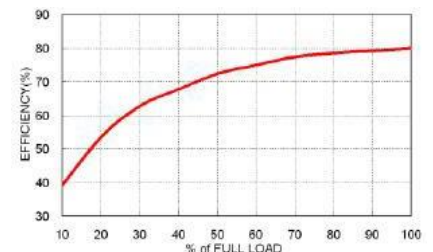

PDS03-48S05W Efficiency vs. Output Load

FUSE CONSIDERATION

This power module is not internally fused. An input line fuse must always be used.

This encapsulated power module can be used in a wide variety of applications, ranging from simple stand-alone operation to an integrated part of sophisticated power architecture.

To maximum flexibility, internal fusing is not included; however, to achieve maximum safety and system protection, always use an input line fuse.

The input line fuse suggest as below :

Model	Fuse Rating (A)	Fuse Type
PDS(H)03-12S□□W, PDS(H)03-12D□□W	2.5	Slow-Blow
PDS(H)03-24S□□W, PDS(H)03-24D□□W	1.5	Slow-Blow
PDS(H)03-48S□□W, PDS(H)03-48D□□W	1	Slow-Blow

The table based on the information provided in this data sheet on inrush energy and maximum DC input current at low Vin.

MECHANICAL DRAWING

PDS03W

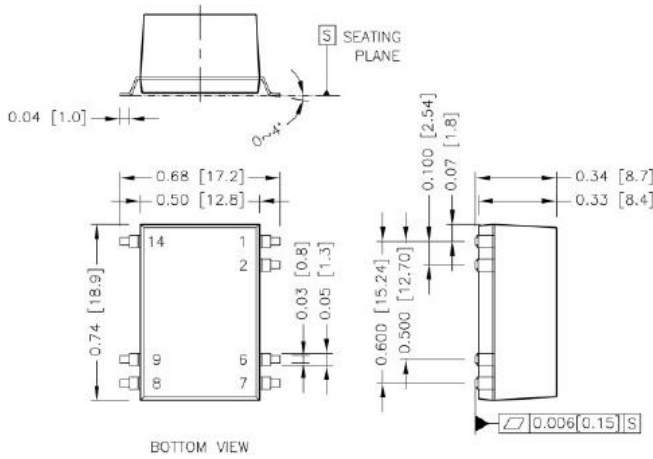

PIN CONNECTION

PIN	SINGLE	DUAL
1	-Vin	-Vin
2	Ctrl	Ctrl
6	NC	Common
7	NC	-Vout
8	+Vout	+Vout
9	-Vout	Common
14	+Vin	+Vin

1. All dimensions in inch [mm]
2. Tolerance :x.xx±0.02 [x.x±0.5]
x.xxx±0.01 [x.xx±0.25]
3. Pin dimension tolerance ±0.004[0.10]

PDH03W

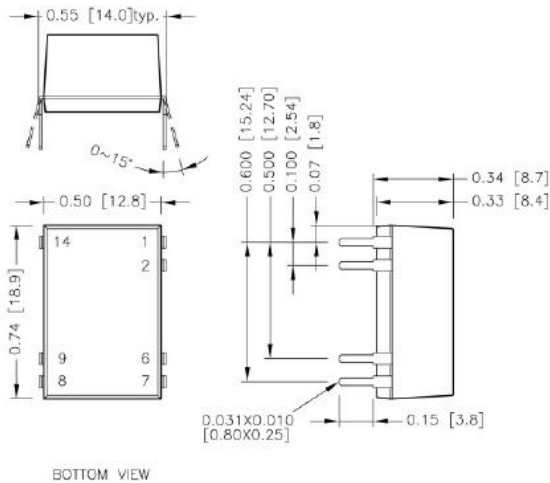

RECOMMENDED PAD LAYOUT

PDS03W

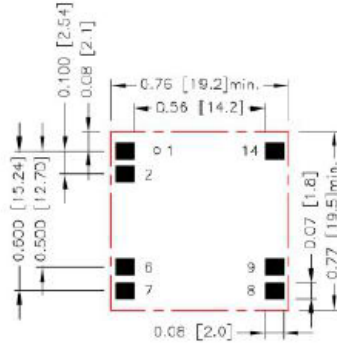

All dimensions in inch[mm]
Pad size(lead free recommended)
Top view pad:0.080x0.070[2.00x1.80]

PDH03W

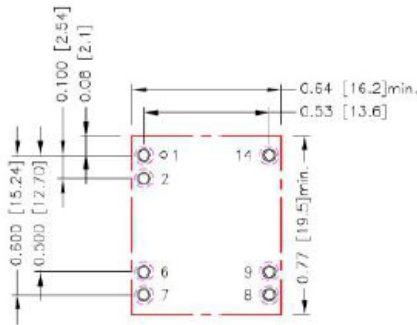

All dimensions in inch[mm]
Pad size(lead free recommended)
Through hole 1.2.6.7.8.9.14: $\Phi 0.043$ [1.10]
Top view pad 1.2.6.7.8.9.14: $\Phi 0.055$ [1.40]
Bottom view pad 1.2.6.7.8.9.14: $\Phi 0.080$ [2.04]

THERMAL CONSIDERATIONS

The power module operates in a variety of thermal environments.

However, sufficient cooling should be provided to help ensure reliable operation of the unit.

Heat is removed by conduction, convection, and radiation to the surrounding environment.

Proper cooling can be verified by measuring the point as the figure below.

The temperature at this location should not exceed "Maximum case temperature".

When operating, adequate cooling must be provided to maintain the test point temperature at or below "Maximum case temperature".

You can limit this temperature to a lower value for extremely high reliability.

- Thermal test condition with vertical direction by natural convection (20LFM).



TOP VIEW

LEAD FREE REFLOW PROFILE For SMD Type

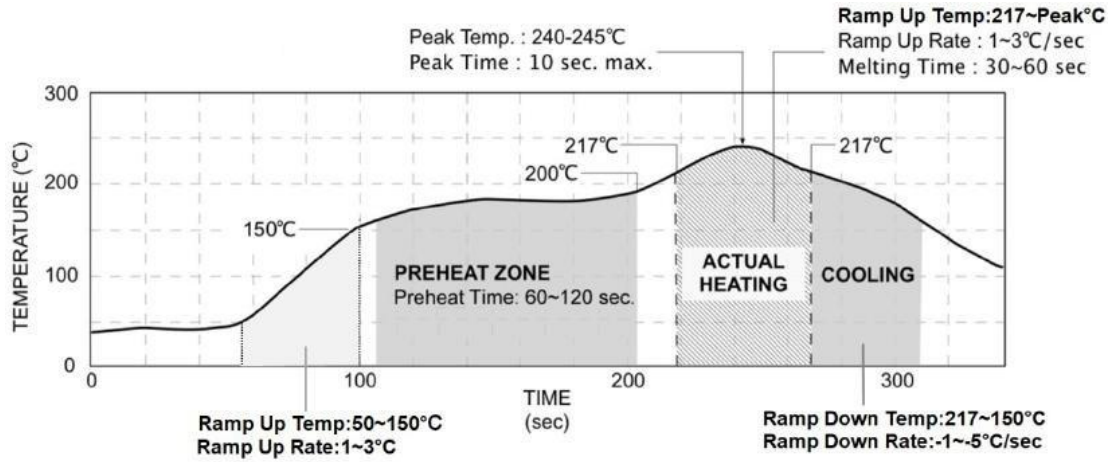

*The curves define the maximum peak reflow temperature permissible measured on pin1 or Vin pin.