



3
YEARS
WARRANTY

ROHS
COMPLIANT

REACH
COMPLIANT



Automation



Datacom



IPC



Industry



Measurement



Telecom



Automobile



Boat



Charger



Medical



PV



Railway



3000
VAC
Isolation
Voltage

ADJ.
Output
Voltage

Internal
EN55032
Class **B**

LOW
Cross
Reg.

LOW
Leakage
Current

LOW
Standby
Power

Operating
Altitude
5000
meter

Protection
Class I
Class II

OPP

OVP

SCP

PART NUMBER STRUCTURE

TAD	40	U						C	- xx	yy	-			
Series Name	Output Power (W)	Input Voltage (VAC)	Output Quantity	Output Voltage 1 (VDC)	Output Voltage 2 (VDC)	Output Voltage 3 Polarity	Output Voltage 3 (VDC)	Protection Type	Vo2 Voltage Code	Vo3 Voltage Code	Connector Options	Application Options	Conformal Coating Options	
				Vo1	Vo2	Vo3 (Triple only)								
A: Open type		U: Universal	D: Dual	3: 5	1: 2.5	M: Minus	1: 2.5	C: CLASS I			<input type="checkbox"/> : JST	<input type="checkbox"/> : None	<input type="checkbox"/> : None	
U: U chassis type		85 ~ 264	T: Triple	4: 7.5	2: 3.3	<input type="checkbox"/> : Positive	2: 3.3	D: CLASS II			M: Molex	C: OVC III	R: Conformal Coating	
E: Enclosed type				5: 9	3: 5		3: 5	<input type="checkbox"/> : CLASS I			T: Terminal Block			
D: Din rail type				6: 12	x: refer to		4: 7.5	(x)NRND						
				7: 15	Suffix xx		5: 9	B: CLASS II						
				8: 18			6: 12	(x)NRND						
				9: 24			7: 15							
				0: 28			8: 18							
							9: 24	※NRND: Not recommended for new designs						
							y: refer to							
							Suffix yy							

TECHNICAL SPECIFICATION All specifications are typical at 230VAC input, full load and 25°C unless otherwise noted

Model Number	Output 1			Output 2			Output 3		Max. Output Power W	Efficiency %	Maximum Capacitor Load µF
	Voltage VDC	Current (Normal) A	Current (MAX) A	Voltage VDC	Current (Normal) A	Current (MAX) A	Voltage VDC	Current (MAX) A			
TAD40UD32C TUD40UD32C TED40UD32C TDD40UD32C	+5	5	8	+3.3	4	6	---	---	40	89.5	12000 / 2000
TAD40UD63C TUD40UD63C TED40UD63C TDD40UD63C	+12	2.1	3.34	+5	4	6	---	---	40	89	1750 / 2000
TAD40UD62C TUD40UD62C TED40UD62C TDD40UD62C	+12	2.1	3.34	+3.3	4	6	---	---	40	90	1750 / 2000
TAD40UD73C TUD40UD73C TED40UD73C TDD40UD73C	+15	1.7	2.67	+5	4	6	---	---	40	88.5	1670 / 2000
TAD40UD93C TUD40UD93C TED40UD93C TDD40UD93C	+24	1.05	1.67	+5	4	6	---	---	40	86	440 / 2000
TAD40UD03C TUD40UD03C TED40UD03C TDD40UD03C	+28	0.72	1.43	+5	4	6	---	---	40	85.5	220 / 2000
TAD40UT32M3C TUD40UT32M3C TED40UT32M3C TDD40UT32M3C	+5	5	8	+3.3	4	6	-5	0.5	40	89	10000 / 2000 / 420
TAD40UT326C TUD40UT326C TED40UT326C TDD40UT326C	+5	5	8	+3.3	4	6	+12	0.5	40	89	10000 / 2000 / 420
TAD40UT32M6C TUD40UT32M6C TED40UT32M6C TDD40UT32M6C	+5	5	8	+3.3	4	6	-12	0.5	40	89	10000 / 2000 / 420
TAD40UT63M3C TUD40UT63M3C TED40UT63M3C TDD40UT63M3C	+12	2.1	3.34	+5	4	6	-5	0.5	40	88.5	1750 / 2000 / 420
TAD40UT63M6C TUD40UT63M6C TED40UT63M6C TDD40UT63M6C	+12	2.1	3.34	+5	4	6	-12	0.5	40	88	1750 / 2000 / 420

Model Number	Output 1			Output 2			Output 3		Max. Output Power	Efficiency	Maximum Capacitor Load
	Voltage	Current (Normal)	Current (MAX)	Voltage	Current (Normal)	Current (MAX)	Voltage	Current (MAX)			
	VDC	A	A	VDC	A	A	VDC	A			
TAD40UT623C TUD40UT623C TED40UT623C TDD40UT623C	+12	2.1	3.34	+3.3	4	6	+5	0.5	40	88.5	1750 / 2000 / 420
TAD40UT62M6C TUD40UT62M6C TED40UT62M6C TDD40UT62M6C	+12	2.1	3.34	+3.3	4	6	-12	0.5	40	88	1750 / 2000 / 420
TAD40UT73M7C TUD40UT73M7C TED40UT73M7C TDD40UT73M7C	+15	1.7	2.67	+5	4	6	-15	0.5	40	88	1670 / 2000 / 420
TAD40UT936C TUD40UT936C TED40UT936C TDD40UT936C	+24	1.05	1.67	+5	4	6	+12	0.5	40	86	440 / 2000 / 420
TAD40UT93M6C TUD40UT93M6C TED40UT93M6C TDD40UT93M6C	+24	1.05	1.67	+5	4	6	-12	0.5	40	86	440 / 2000 / 420

INPUT SPECIFICATIONS						
Parameter	Conditions	Min.	Typ.	Max.	Unit	
Operating input voltage range	AC input	85		264	VAC	
	DC input	120		370	VDC	
Input frequency	AC input	47		63	Hz	
Input current	100VAC			1.05	A	
	240VAC			0.55		
No load input power	230VAC		0.15		Watts	
Leakage current	264VAC		75		µA	
Start up time				1000	ms	
Rise time			20		ms	
Hold up time	115VAC and Full Load		25		ms	
Input inrush current	230VAC		60		A	
Input protection	Internal fuse		T3.15A/250VAC			

OUTPUT SPECIFICATIONS						
Parameter	Conditions		Min.	Typ.	Max.	Unit
Output power	Pout 1+Pout 2+Pout 3				40	Watts
Initial set voltage accuracy	230VAC and Full Load	Vout 1	-1.0		+1.0	%
		Vout 2, Vout 3	-2.0		+2.0	
Line regulation	Low Line to High Line at Full Load		-0.2		+0.2	%
Load regulation	No Load to Full Load	Vout 1	-0.5		+0.5	%
		Vout 3	-0.7		+0.7	
	No Load to Full Load	Vout 2	-1.5		+1.5	%
	0.1W Load to Full Load		-0.7		+0.7	%
Cross regulation	Asymmetrical load 25%/100% FL		-1.5		+1.5	%
Voltage adjustability		Vout 1	-10		+10	%
Minimum load	T□D40UD□□□			0		W
	T□D40OUT□□□□; Vout 3 is full load	Vout 1+Vout 2		0.5		
Ripple and noise	Measured by 20MHz bandwidth					mVp-p
	With a 10µF/25V 1206 X7R MLCC	Vout 1 5V		100		
		Vout 1 12V		120		
		15V		150		
		24V		240		
	With a 10µF/25V 1206 X7R MLCC	Vout 2 All		100		
Vout 3 5V			100			
		12V		120		
		15V		150		
Temperature coefficient			-0.02		+0.02	%/°C
Transient response	Load step form 50 ~ 75% change at 2.5A/µs	Vout 1 Peak deviation		600	3	%Vout
		Recovery time				µs
Over voltage protection	% of Vout(nom); Latch mode	Vout 1	125		140	%
Over power protection	% of nominal output power; Hiccup mode	Pout 1+Pout 2		145		%
Short circuit protection			Continuous, automatics recovery			

GENERAL SPECIFICATIONS						
Parameter	Conditions		Min.	Typ.	Max.	Unit
Isolation voltage	1 minute (Reinforced insulation)	Input to Output	3000			VAC
		Input (Output) to F.G.	2500			
Isolation resistance	500VDC		0.1			GΩ
Switching frequency	230VAC	Vout 1 5V		70		kHz
		Others		115		
		Vout 2		750		
		Vout 3		510		
Safety approvals	IEC/ EN/ UL 62368-1					UL:E193009 CB:UL(Demko)
Weight		TAD				150 (5.29oz)
		TUD				198 (6.98oz)
		TED				216 (7.62oz)
		TDD				238 (8.40oz)
MTBF	MIL-HDBK-217F, Full load					1.716 x 10 ⁶ hrs

ENVIRONMENTAL SPECIFICATIONS						
Parameter	Conditions		Min.	Typ.	Max.	Unit
Operating ambient temperature	Natural convection	With derating	-40		+85	°C
Storage temperature range			-40		+85	°C
Operating altitude					5000	m
Shock						IEC60068-2-27
Vibration						IEC60068-2-6
Relative humidity	Non-condensing					5% to 95% RH

EMC SPECIFICATIONS			
Parameter	Conditions		Level
EMI	EN55032 and FCC Part 15		Conducted
	External components may be required for class I application.		Radiated
Harmonic currents	EN61000-3-2	Full Load	Class B
Voltage flicker	EN61000-3-3		Class B
EMS	EN55024 and Complies with EN 61850-3		
ESD	EN61000-4-2		Perf. Criteria A
Radiated immunity	EN61000-4-3	20 V/m	Perf. Criteria A
Fast transient	EN61000-4-4	$\pm 4kV$	Perf. Criteria A
Surge	EN61000-4-5	DM $\pm 2kV$ and CM $\pm 4kV$	Perf. Criteria A
Conducted immunity	EN61000-4-6	20 Vr.m.s	Perf. Criteria A
Power frequency magnetic field	EN61000-4-8	100 A/m	Perf. Criteria A
Dip and interruptions	EN61000-4-11		
Damped oscillatory wave	EN61000-4-18	DM $\pm 1kV$ and CM $\pm 2.5kV$	Perf. Criteria A

CHARACTERISTIC CURVE

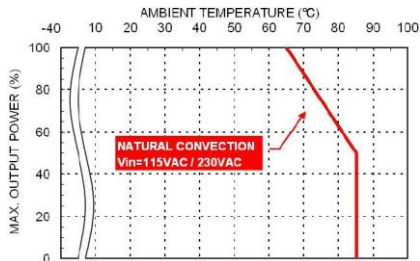

TAD40UD Derating Curve vs. Ambient Temperature

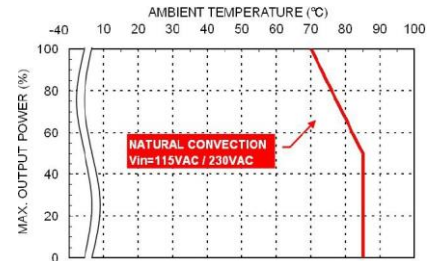

TAD40UT Derating Curve vs. Ambient Temperature

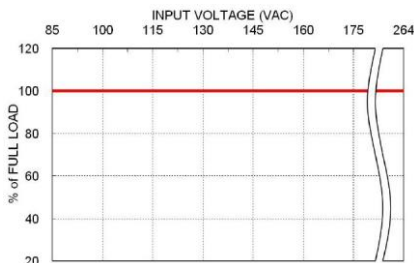

TAD40 Derating Curve vs. Input Voltage

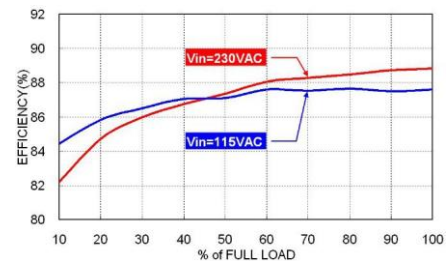

TAD40UT63M6B Efficiency vs. Output Load



TAD40UT63M6B Efficiency vs. Input Voltage

MECHANICAL DRAWING

TAD Open type

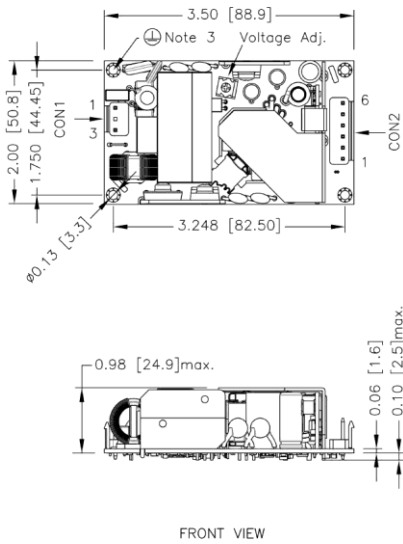

FRONT VIEW

1. All dimensions in inch[mm]
Tolerance: x.xx±0.02[x.x±0.5] x.xxx±0.010[x.xx±0.25]
2. The screw locked torque: MAX 5.0kgf-cm/0.49N-m
3. The screws holes can be considered as PE connection for CLASS I application.

TDD Din rail type

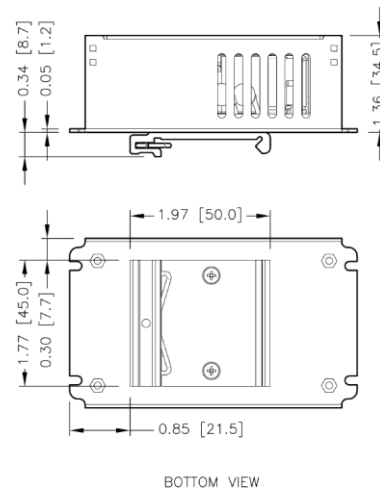

BOTTOM VIEW

1. All dimensions in inch[mm]
Tolerance: x.xx±0.02[x.x±0.5] x.xxx±0.010[x.xx±0.25]
2. The screw locked torque: MAX 5.0kgf-cm/0.49N-m

TED Enclosed type

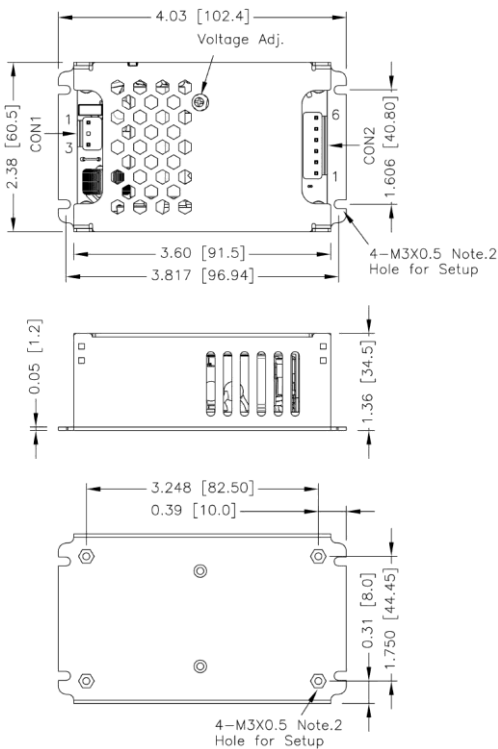

BOTTOM VIEW

1. All dimensions in inch[mm]
Tolerance: x.xx±0.02[x.x±0.5] x.xxx±0.010[x.xx±0.25]
2. The screw locked torque: MAX 5.0kgf-cm/0.49N-m

TUD U chassis type

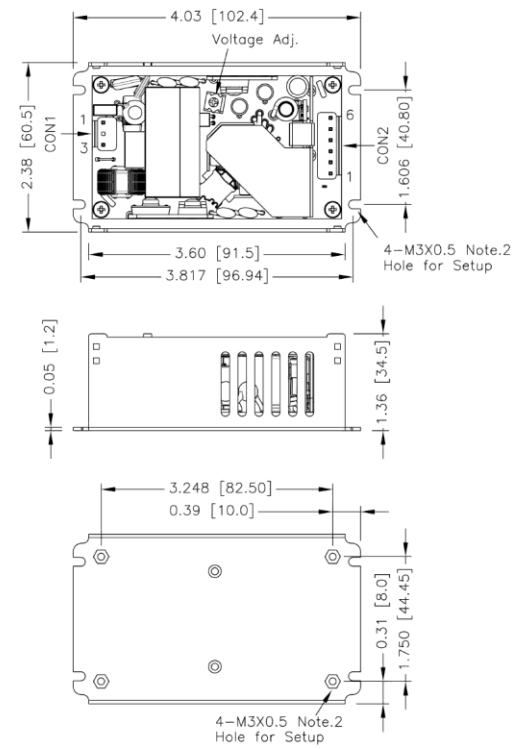

BOTTOM VIEW

1. All dimensions in inch[mm]
Tolerance: x.xx±0.02[x.x±0.5] x.xxx±0.010[x.xx±0.25]
2. The screw locked torque: MAX 5.0kgf-cm/0.49N-m

CONNECTOR CONNECTIONS

CON1 – Input Connector

Pin Number	AC Input	DC Input
		T□D40UDXXC、T□D40UDXXD T□D40UTXXC、T□D40UTXXD
Pin 1	Line	DC+
Pin 3	Neutral	DC-

CON2 – Output Connector

Pin 1	Vout3
Pin 2,3	Com
Pin 4,5	Vout2
Pin 6	Vout1

*Either one of four screws holes of Chassis type can be considered as PE connection for CLASS I application.

CONNECTOR OPTIONS

Blank: JST Type



Mates with housing
CON1: **VHR-3N**
CON2: **VHR-6N**

Crimp terminals
CON1: **SVH-21T-P1.1**
CON2: **SVH-21T-P1.1**

-M Molex Type



Mates with housing
CON1: **09-50-8031**
CON2: **09-50-8061**

Crimp terminals
CON1: **SD-2478**
CON2: **SD-2478**

-T Terminal Block



Screw locked torque
MAX 2Kgf.cm/0.2N.m

Wire dimension range
26 ~ 16AWG