



3
YEARS
WARRANTY

ROHS
COMPLIANT

REACH
COMPLIANT

+85°C
-40°C
AMBIENT TEMP.



Automation



Datacom



IPC



Industry



Measurement



Telecom



Automobile



Boat



Charger



Medical



PV



Railway



3000 VAC
Reinforced
Insulation

ADJ.
Output
Voltage

Internal
EN55032
Class **B**
Filter

LOW
Leakage
Current

LOW
Standby
Power

Protection
Class I
Class II

Operating
Altitude
5000
meter

OCP

OVP

SCP

PART NUMBER STRUCTURE

T	A	F	150	U	S	12	B	-	□	□	□	□
Application	Package Code	Dimension Code	Output Power (W)	Input Voltage (VAC)	Output Quantity	Output Voltage (VDC)	Protection Type	Connector Options	Application Options	Fan Options	Conformal Coating Options	
Industry Application	A: Open type U: U chassis type E: Enclosed type D: Din rail type			U: Universal 85 ~ 264	S: Single	12: 12 15: 15 24: 24 28: 28 36: 36 48: 48	B: CLASS II □: CLASS I	□: JST M: Molex T: Terminal Block	□: None C: OVC III	□: None F: External FAN (for TEF/ TDF)	□: None R: Conformal Coating	

TECHNICAL SPECIFICATION All specifications are typical at 230VAC input, full load and 25°C unless otherwise noted

Model Number	Input Range VAC	Output Voltage VDC	Output Current		Efficiency %	Maximum Capacitor Load µF
			Natural Convection A	Forced Air Cooling With 10CFM / Option with Fan A		
TAF150US12B	85 ~ 264	12	8.34	12.5	91	10400
TUF150US12B			8.34			
TEF150US12B			10.84			
TDF150US12B			10.84			
TAF150US15B	85 ~ 264	15	7.34	10	92	6600
TUF150US15B			7.34			
TEF150US15B			9			
TDF150US15B			9			
TAF150US24B	85 ~ 264	24	4.59	6.25	92	2600
TUF150US24B			4.59			
TEF150US24B			5.63			
TDF150US24B			5.63			
TAF150US28B	85 ~ 264	28	3.93	5.36	92	1900
TUF150US28B			3.93			
TEF150US28B			4.83			
TDF150US28B			4.83			
TAF150US36B	85 ~ 264	36	3.06	4.17	92	1150
TUF150US36B			3.06			
TEF150US36B			3.75			
TDF150US36B			3.75			
TAF150US48B	85 ~ 264	48	2.09	3.13	92	650
TUF150US48B			2.09			
TEF150US48B			2.71			
TDF150US48B			2.71			

INPUT SPECIFICATIONS

Parameter	Conditions	Min.	Typ.	Max.	Unit
Operating input voltage range	AC input	85		264	VAC
	DC input	120		370	VDC
Input frequency	AC input	47		63	Hz
Input current	115VAC and Full Load			1.7	A
	230VAC and Full Load			0.8	
No load input power	230VAC		0.6		Watts
	230VAC			0.3	
Leakage current	264VAC			300	µA
Power Factor		0.95			
Start up time				1000	ms
Rise time			20		ms
Hold up time	115VAC and Full Load	16			ms
Input inrush current	230VAC			100	A
Input protection	Internal fuse			T3.15A/250VAC	

OUTPUT SPECIFICATIONS						
Parameter	Conditions		Min.	Typ.	Max.	Unit
Output power	Forced air cooling with 10CFM or Option -F Natural convection for 15Vout, 24Vout, 28Vout, 36Vout Natural convection for 12Vout, 48Vout				150 110 100	Watts
Initial set voltage accuracy	230VAC and Full Load		-1.0		+1.0	%
Line regulation	Low Line to High Line at Full Load		-0.2		+0.2	%
Load regulation	No Load to Full Load 10% Load to 90% Load		-0.5 -0.4		+0.5 +0.4	%
Voltage adjustability			-10		+10	%
Minimum load				0		%
Ripple and noise	Measured by 20MHz bandwidth With a 1µF/25V 1206 X7R MLCC 12Vout 15Vout With a 1µF/50V 1206 X7R MLCC 24Vout 28Vout 36Vout With a 0.1µF/100V 1206 X7R MLCC 48Vout			120 150 220 220 250 250		mVp-p
Temperature coefficient			-0.02		+0.02	%/°C
Transient response	Load step from 50 ~ 75% change at 2.5A/µs	Peak deviation Recovery time		500	3	% Vout µs
Over voltage protection	% of Vout(nom); Latch mode		115		135	%
Over load protection	% of Iout rated; Hiccup mode		115		150	%
Short circuit protection			Continuous, automatics recovery			
Fan power supply			12V at 500mA			

GENERAL SPECIFICATIONS						
Parameter	Conditions		Min.	Typ.	Max.	Unit
Isolation voltage	1 minute (Reinforced insulation)	Input to Output Input (Output) to F.G.	3000 2000			VAC
Isolation resistance	500VDC		0.1			GΩ
Switching frequency				60		kHz
Safety approvals	IEC/ EN/ UL 62368-1 (OVC III)		UL:E193009 CB:UL(Demko)			
Weight		TAF TUF TEF TDF			187g (6.60oz) 235g (8.29oz) 256g (9.03oz) 278g (9.81oz)	
MTBF	MIL-HDBK-217F Ta=25°C, Full load				7.861 x 10 ⁵	hrs

ENVIRONMENTAL SPECIFICATIONS						
Parameter	Conditions		Min.	Typ.	Max.	Unit
Operating ambient temperature	With derating	Option -F (With Fan) Others	-40 -40		+80 +85	°C °C
	-40°C start up : 80% Load,max. @ Vin > 100VAC -40°C start up : 100% Load,max. @ Vin > 200VAC					
Storage temperature range		Option -F (With Fan) Others	-40 -40		+75 +85	°C °C
Operating altitude					5000	m
Shock			IEC60068-2-27			
Vibration			IEC60068-2-6			
Relative humidity	Non-condensing		5% to 95% RH			

EMC SPECIFICATIONS			
Parameter	Conditions		Level
EMI	EN55032 and FCC Part 15		Conducted Class B
	External components may be required for class I application.		Radiated Class A
Harmonic currents	EN61000-3-2	Full Load	Class A and D
Voltage flicker	EN61000-3-3		
EMS	EN55024		
ESD	EN61000-4-2		Perf. Criteria A
Radiated immunity	EN61000-4-3	20 V/m	Perf. Criteria A
Fast transient	EN61000-4-4	± 2kV	Perf. Criteria A
Surge	EN61000-4-5	DM ± 1kV and CM ± 2kV	Perf. Criteria A
Conducted immunity	EN61000-4-6	20 Vr.m.s	Perf. Criteria A
Power frequency magnetic field	EN61000-4-8	10 A/m	Perf. Criteria A
Dip and interruptions	EN61000-4-11		

CHARACTERISTIC CURVE

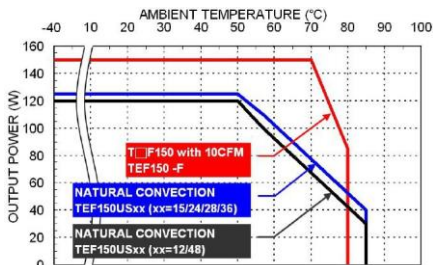

Derating Curve vs. Ambient Temperature
Vin=115VAC

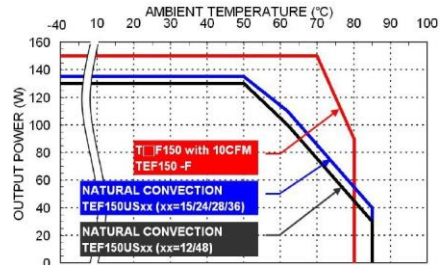

Derating Curve vs. Ambient Temperature
Vin=230VAC

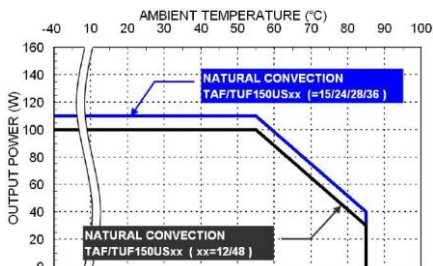

Derating Curve vs. Ambient Temperature
Vin=115VAC

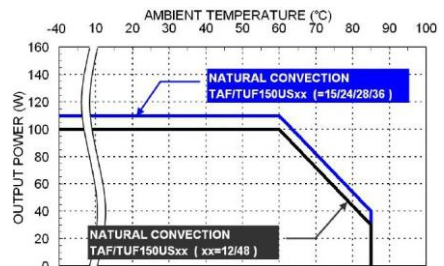

Derating Curve vs. Ambient Temperature
Vin=230VAC

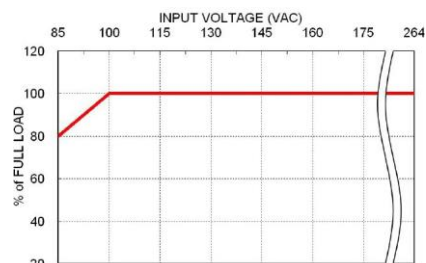

T1: F150 Derating Curve vs. Input Voltage

CHARACTERISTIC CURVE(CONTINUED)

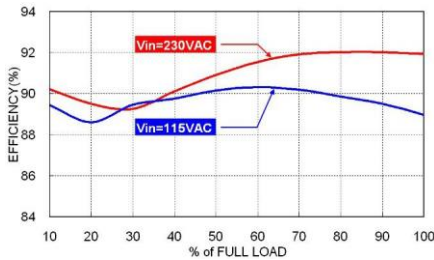

TAF150US24B Efficiency vs. Output Load

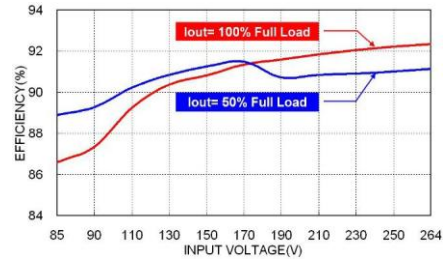

TAF150US24B Efficiency vs. Input Voltage

MECHANICAL DRAWING

TAF Open type

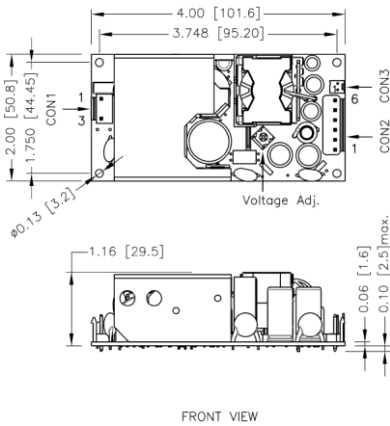

TDF Din rail type

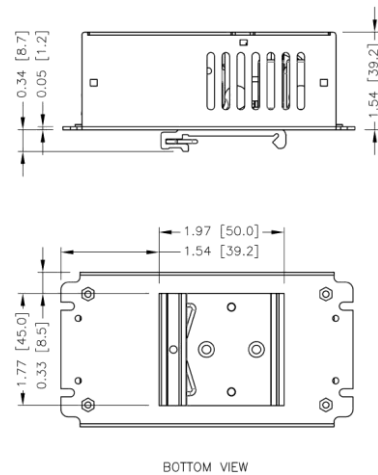

- All dimensions in inch [mm]
Tolerance : x.xx±0.02 [x.x±0.5] x.xxx±0.01 [x.xx±0.25]
- M3x0.5 screw locked torque MAX 5Kgf.cm/0.49N.m

CONNECTORS CONNECTIONS

CON1 – Input Connector

Pin 1	Line
Pin 3	Neutral

CON2 – Output Connector

Pin 1,2,3	-Vout
Pin 4,5,6	+Vout

CON3 – Fan Connector

Pin 1	-Fan
Pin 2	+Fan

Mates with
Molex housing : **22-01-1022**
Molex crimp terminals : **2759**

*Either one of four screws holes of Open / Chassis type can be considered as PE connection for CLASS I application.

MECHANICAL DRAWING

TEF Enclosed type

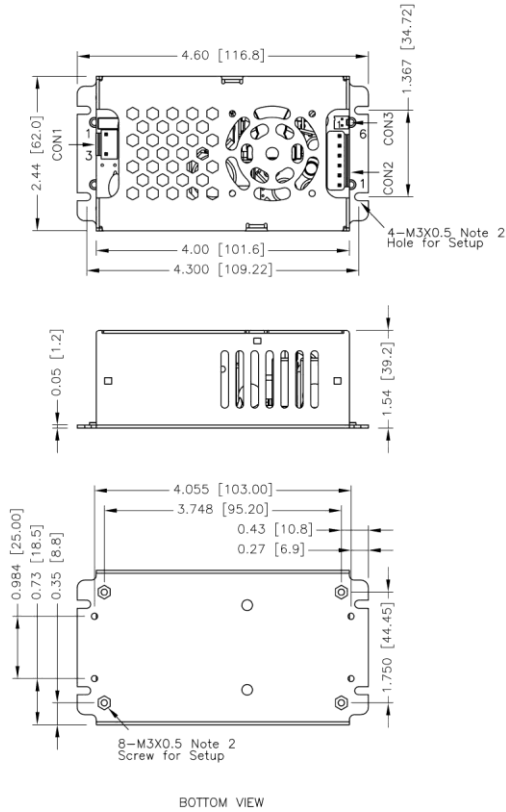

TUF U chassis type

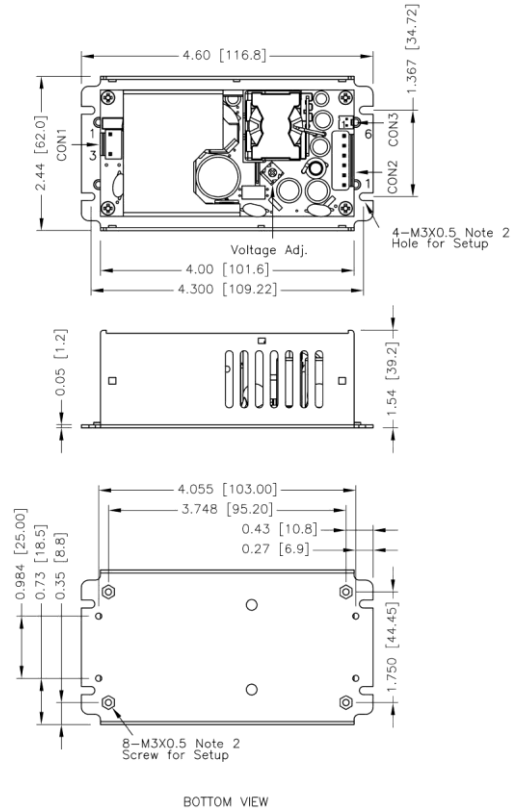

- All dimensions in inch [mm]
Tolerance : x.xx±0.02 [x.x±0.5] x.xxx±0.01 [x.xx±0.25]
- M3x0.5 screw locked torque MAX 5Kgf.cm/0.49N.m

CONNECTORS CONNECTIONS

CON1 – Input Connector	
Pin 1	Line
Pin 3	Neutral

CON2 – Output Connector	
Pin 1,2,3	-Vout
Pin 4,5,6	+Vout

CON3 – Fan Connector	
Pin 1	-Fan
Pin 2	+Fan

Mates with
Molex housing : **22-01-1022**
Molex crimp terminals : **2759**

*Either one of four screws holes of Open / Chassis type can be considered as PE connection for CLASS I application.

MECHANICAL DRAWING (CONTINUED)

TEF -E Enclosed type with FAN

TDF -E Din rail type with FAN

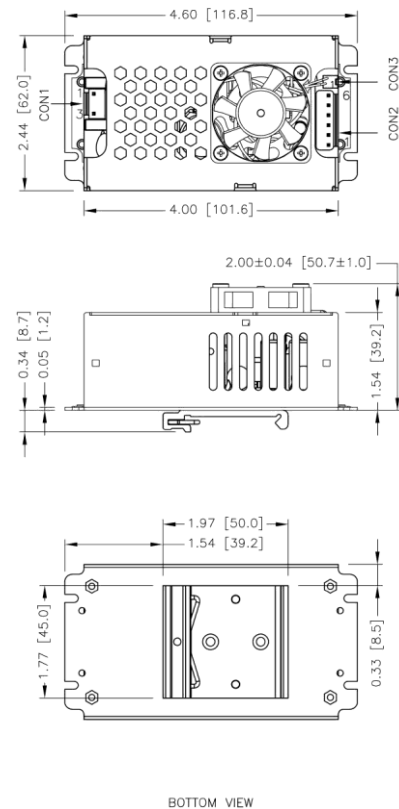
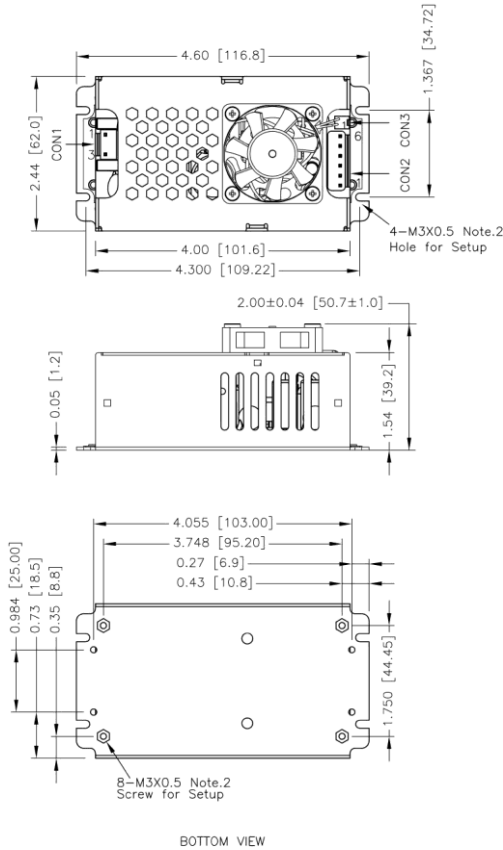

- All dimensions in inch [mm]
Tolerance : x.xx±0.02 [x.x±0.5] x.xxx±0.01 [x.xx±0.25]
- M3x0.5 screw locked torque MAX 5Kgf.cm/0.49N.m

CONNECTORS CONNECTIONS

CON1 – Input Connector	
Pin 1	Line
Pin 3	Neutral

CON2 – Output Connector	
Pin 1,2,3	-Vout
Pin 4,5,6	+Vout

CON3 – Fan Connector	
Pin 1	-Fan
Pin 2	+Fan

Mates with
Molex housing : **22-01-1022**
Molex crimp terminals : **2759**

*Either one of four screws holes of Open / Chassis type can be considered as PE connection for CLASS I application.

CONNECTOR OPTIONS

Blank:

JST Type

Mates with housing

CON1: **VHR-3N**

CON2: **VHR-6N**

Crimp terminals

CON1: **SVH-21T-P1.1**

CON2: **SVH-21T-P1.1**



-M

Molex Type

Mates with housing

CON1: **09-50-8031**

CON2: **09-50-8061**

Crimp terminals

CON1: **SD-2478**

CON2: **SD-2478**



-T

Terminal Block

Screw locked torque

MAX 2Kgf.cm/0.2N.m

Wire dimension range

26 ~ 16AWG



EXTERNAL FAN OPTION

There is an external fan option for TEF and TDF. The fan's life is shorter than power supply and has only 2 years warranty. Here are specifications for replacement.

Fan dimensions	40 x 40 x 10 mm
Air flow	7 CFM

